

- 2 channels sampled at 16-bit resolution
- 125 MS/s simultaneous real-time sampling rate on each input
- $\pm 200\text{mV}$ to $\pm 16\text{V}$ input range
- Up to 128 Million samples of on-board acquisition memory per channel
- Dual Port Memory
- AlazarDSO Oscilloscope Software
- Optional Data Streaming To Hard Disk
- Software Development Kit supports C/C++, C#, MATLAB and LabVIEW.
- Linux drivers available

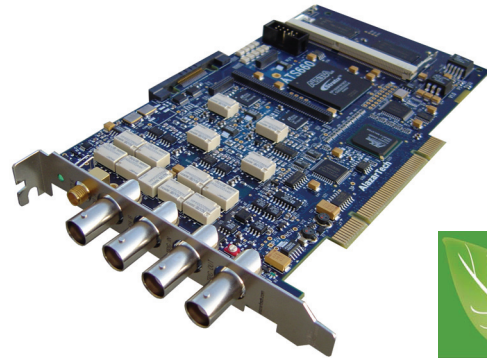

Product	Bus	Operating System	Channels	Sampling Rate	Bandwidth	Memory Per Channel	Resolution
ATS660	PCI 32 bit 33 MHz	Win XP/Vista/7, Linux 2.6+ 32bit/64 bit	2	125 MS/s to 1 KS/s	65 MHz	Up to 128 Msamples	16 bits

Overview

ATS660 is a state of the art, dual-channel, high resolution, 16 bit, 125 MS/s waveform digitizer card for PCI bus, capable of storing up to 128 Million samples per channel of acquired data in its on-board memory.

With standard Dual Port Memory and fully asynchronous DMA, ATS660 allows users to build Windows or Linux based real-time data acquisition systems. Users are allowed to read acquired data even while the acquisition is in progress, including the ability to stream data to disk at rates up to 50 MS/s on one channel and 25 MS/s on 2 channels, simultaneously.

ATS660 PCI digitizers are an ideal solution for cost sensitive OEM applications that require a digitizer to be embedded into the customer's equipment.

For scientific customers who want to record multiple analog inputs simultaneously, ATS660 offers the best price-performance ratio for multi-channel data acquisition systems of up to 16 channels. Even higher channel counts are possible as a special order item.

ATS660 is supplied with AlazarDSO oscilloscope software that lets the user get started immediately without having to write any software.

Users who need to integrate the ATS660 in their own program can purchase a Windows based software development kit, ATS-SDK for C/C++, C# and MATLAB, or ATS-VI for LabVIEW for Windows or a Linux based ATS-Linux.

All of this advanced functionality is packaged in a low power, half-length PCI card available at a very aggressive price point.

Applications

- **Optical Coherence Tomography (OCT)**
- **Ultrasonic & Eddy Current NDT/NDE**
- **Radar/RF Signal Recording & Analysis**
- **Terabyte Storage Oscilloscope**
- **High Resolution Oscilloscope**
- **Lidar**
- **Spectroscopy**
- **Digital Down Conversion (DDC)**
- **Multi-Channel Transient Recording**

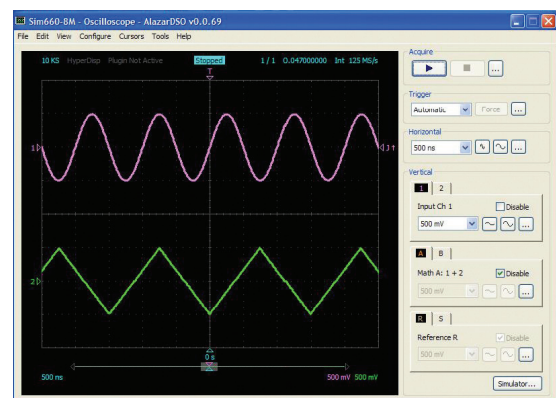

Analog Input

An ATS660 features two analog input channels with extensive functionality. Each channel has 65 MHz of full power analog input bandwidth. With software selectable attenuation, you can achieve an input voltage range of $\pm 200\text{mV}$ to $\pm 16\text{V}$. Attenuating probes (sold separately) can extend the voltage range even higher.

Software selectable AC or DC coupling further increases the signal measurement capability. Software selectable 50Ω input impedance makes it easy to interface to high speed RF signals.

For applications that require the best signal integrity, an Amplifier Bypass Mode is available as a standard feature. This feature increases the SNR to 75 dB, increases input bandwidth to 85 MHz while leaving the input range fixed at a nominal value of $\pm 575\text{ mV}$.

Acquisition System

ATS660 PCI digitizers use a pair of state of the art 125 MS/s, 16-bit ADCs to digitize the input signals. The real-time sampling rate ranges from 125 MS/s down to 1 KS/s. The two channels are guaranteed to be simultaneous, as they share the exact same clock.

An acquisition can consist of multiple records, with each record being captured as a result of one trigger event. A record may contain both pre-trigger and post-trigger data.

Up to 256,000 triggers can be captured into on-board memory. There is no limit on number of triggers if dual port memory is used to acquire data.

In between the multiple triggers being captured, the acquisition system is re-armed by the hardware within 32 sampling clock cycles.

This mode of capture, sometimes referred to as Multiple Record, is very useful for capturing data in applications with a very rapid or unpredictable trigger rate. Examples of such applications include medical imaging, ultrasonic testing, OCT, NMR spectroscopy and lightning test.

On-Board Acquisition Memory

The standard ATS660 PCI digitizer features 8 Million points of acquisition memory for each channel.

Acquisition memory can optionally be upgraded to provide 128 Million samples per channel of signal storage.

Data is acquired into the onboard memory before being transferred to the host PC memory. This transfer is performed using Direct Memory Access (DMA), which uses scatter-gather bus mastering technology.

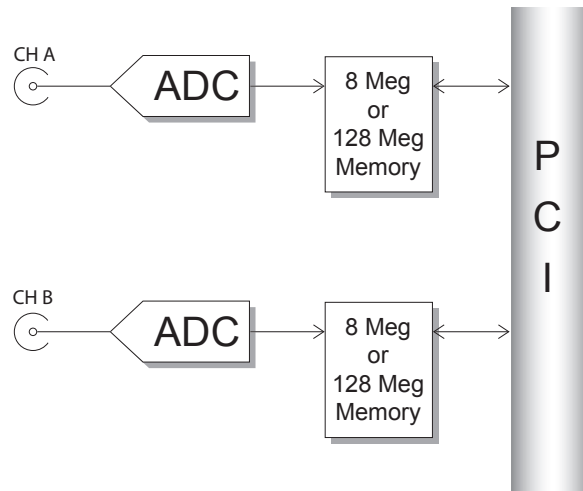

Dual Port Memory

ATS660 is equipped with dual port acquisition memory. This means that data can be transferred to host PC memory even if an acquisition is in progress.

Other digitizers on the market do not provide dual-port memory, thus prolonging the re-arm time of the digitizer. This limits the maximum trigger repeat rate they can handle in applications involving fast triggers, such as OCT, medical imaging, ultrasonic testing, NMR spectroscopy and other pulse-echo testing methodologies.

ATS660 does not suffer from such drawbacks and provides the best solution for these applications.

AlazarTech has designed custom memory management circuitry to interface this dual port memory to PCI bus. This circuitry is called AutoDMA, which can work in many different modes.

Traditional AutoDMA

In order to acquire both pre-trigger and post-trigger data in a dual-ported memory environment, users can use Traditional AutoDMA.

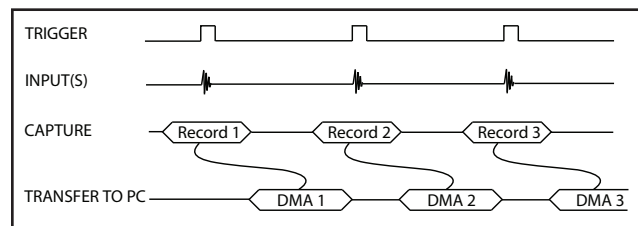

Data is returned to the user in buffers, where each buffer can contain from 1 to 8192 records (triggers). This number is called RecordsPerBuffer.

Users can also specify that each record should come with its own header that contains a 40-bit trigger timestamp.

A BUFFER_OVERFLOW flag is asserted if more than 512 buffers have been acquired by the acquisition system, but not transferred to host PC memory by the AutoDMA engine.

While Traditional AutoDMA can acquire data to PC host memory at sustained rates in excess of 100 MB/s, an overflow can occur if more than 512 triggers occur in very rapid succession, even if all the on-board memory has not been used up.

No Pre-Trigger (NPT) AutoDMA

Many ultrasonic scanning and medical imaging applications do not need any pre-trigger data: only post-trigger data is sufficient.

NPT AutoDMA is designed specifically for these applications. By only storing post-trigger data, the memory bandwidth is optimized and the entire on-board memory acts like a very deep FIFO.

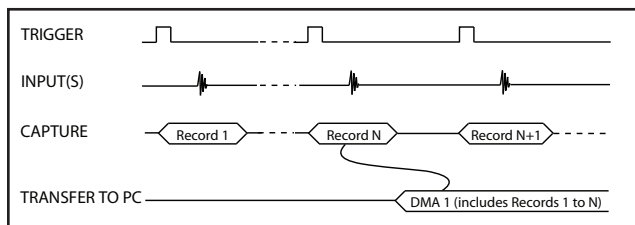

Note that a DMA is not started until RecordsPerBuffer number of records (triggers) have been acquired.

NPT AutoDMA buffers do not include headers, so it is not possible to get trigger time-stamps.

More importantly, a BUFFER_OVERFLOW flag is asserted only if the entire on-board memory is used up. This provides a very substantial improvement over Traditional AutoDMA.

NPT AutoDMA can easily acquire data to PC host memory at sustained rates in excess of 100 MB/s without causing an overflow.

This is the recommended mode of operation for most ultrasonic scanning, OCT and medical imaging applications.

Continuous AutoDMA

Continuous AutoDMA is also known as the data streaming mode.

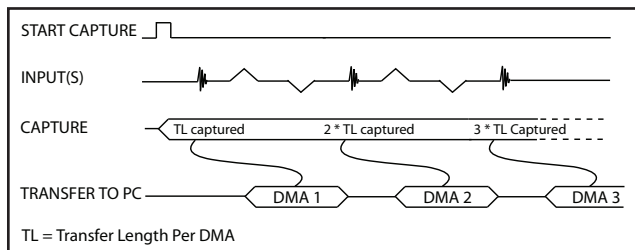

In this mode, data starts streaming across the PCI bus as soon as the ATS660 is armed for acquisition. It is important to note that triggering is disabled in this mode.

Continuous AutoDMA buffers do not include headers, so it is not possible to get trigger time-stamps.

A BUFFER_OVERFLOW flag is asserted only if the entire on-board memory is used up.

The amount of data to be captured is controlled by counting the number of buffers acquired. Acquisition is stopped by an AbortCapture command.

Continuous AutoDMA can easily acquire data to PC host memory at sustained rates in excess of 100 MB/s without causing an overflow. This is the recommended mode for very long signal recording.

Triggered Streaming AutoDMA

Triggered Streaming AutoDMA is virtually the same as Continuous mode, except the data transfer across the bus is held off until a trigger event has been detected.

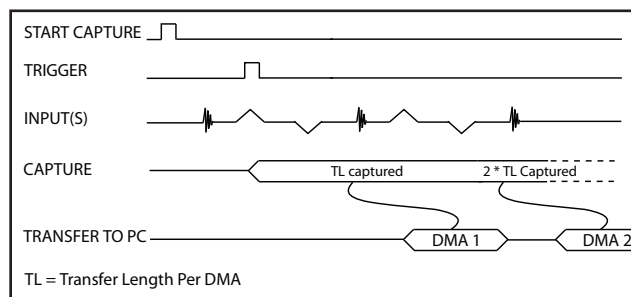

Triggered Streaming AutoDMA buffers do not include headers, so it is not possible to get trigger time-stamps.

A BUFFER_OVERFLOW flag is asserted only if the entire on-board memory is used up.

As in Continuous mode, the amount of data to be captured is controlled by counting the number of buffers acquired. Acquisition is stopped by an AbortCapture command.

Triggered Streaming AutoDMA can easily acquire data to PC host memory at sustained rates in excess of 100 MB/s without causing an overflow. This is the recommended mode for RF signal recording that has to be started at a specific time, e.g. based on a GPS pulse.

Asynchronous DMA

AlazarTech's dual port memory and AutoDMA circuit maximize throughput at the hardware level. An equally sophisticated software architecture is required to allow a Windows or Linux based application program



ATS660

125 MS/s 16-Bit PCI Digitizer

to take advantage of this throughput despite all the bottlenecks created by the operating system.

AlazarTech calls this architecture *Asynchronous DMA* or AsyncDMA.

AsyncDMA uses overlapped IO to re-start DMAs and consume data, thereby minimizing CPU usage to almost 0%, reducing re-arm time of DMAs and allowing the full bus bandwidth to be realized.

Another advantage of AsyncDMA is that it can provide the full bus bandwidth to a multi-card Master/Slave system.

Some helper routines are provided for programming languages that cannot directly use overlapped IO. Examples of such languages include Visual BASIC and LabVIEW.

It is important to note that AsyncDMA is a software construct and it can be used with any of the AutoDMA modes mentioned before.

Stream To Disk

Any one of the AutoDMA modes can be combined with a fast disk drive to create a very efficient and low cost data streaming system.

AlazarDSO Stream To Disk module allows out-of-the-box disk streaming. No programming is required.

Files are saved as ATB format binary files. Optionally, user can set up AlazarDSO to automatically convert these ATB files to level 5 MAT-File format for export to MATLAB.

For more information on complete disk streaming systems, please contact the factory or your local distributor.

FPGA Customization

A number of OEM applications require real-time signal processing of the digitized data. ATS660 contains a large Altera Stratix FPGA with ample resources, including hardware multipliers, to implement FIR filters, demodulation, IQ detection, DDC, FFT etc.

Results of any on-board data processing can be streamed to host PC memory or disk drive using the Continuous or Triggered Streaming AutoDMA described earlier.

All customization work must be done at AlazarTech factory. Contact the factory to discuss your specific needs.

Software Selectable Bandwidth Limit

A majority of applications for PCI digitizers require oversampling of input signal, i.e. the frequency of the analog signal being digitized is a factor of 5 or 6 lower than the sample rate or even the Nyquist rate.

ATS660 features a software-controlled bandwidth limit switch, which reduces high frequency noise and improves signal to noise ratio. This switch is independently selectable for each input channel.

When selected, bandwidth limit switch can reduce the input bandwidth of a particular input to be approximately 20 MHz.

Amplifier Bypass Mode

To obtain optimum dynamic performance, choose the Amplifier Bypass Mode.

Each channel can be independently bypassed using on-board DIP-switches.

Once the amplifier has been bypassed, the input for that channel has 50 Ω impedance, DC coupling and a 575 mV full scale input range. Diode protection is still included, but users should avoid saturation of the input beyond 120% of full scale.

Display of Very Large Data Sets

Capturing a very large amount of data is only part of the solution the ATS660 offers. ATS660 also provides very fast rendering of this data on the computer screen.

Most products on the market that provide large amount of storage memory use standard Windows display routines to plot data on the screen. This is extremely slow and can take many minutes to update the screen. Many software packages, such as LabVIEW, explicitly warn against using large data arrays.

ATS660 uses custom HyperDisP display management technology to render these very large datasets on the computer screen in a fraction of a second.

Triggering

The ATS660 is equipped with sophisticated digital triggering options, such as programmable trigger thresholds and slope on any of the input channels or the External Trigger input.

While most oscilloscopes offer only one trigger engine, ATS660 offers two trigger engines (called Engines X and Y). This allows the user to combine the two engines using a logical OR, AND or XOR operand.

The user can specify the number of records to capture in an acquisition, the length of each record and the amount of pre-trigger data.

A programmable trigger delay can also be set by the user. This is very useful for capturing the signal of interest in a pulse-echo application, such as ultrasound, radar, lidar etc.

Trigger Time Stamp

A 40-bit time stamp counter comes standard with the ATS660. By default, this counter is initialized to



ATS660

125 MS/s 16-Bit PCI Digitizer

a zero value when an acquisition session is started and increments once for every two samples captured, thus providing a 2-clock timing accuracy. At 125 MS/s sample rate, this counter will not roll over for well over 2 hours.

The value of this counter is latched into trigger memory for each trigger, i.e. once per record, for up to specified number of records.

This allows the user to find out the timing of each trigger in a multiple record acquisition relative to the start of the acquisition.

It is also possible to configure the timestamp counter to reset for the first acquisition only and never again, until a software reset is issued. This feature enables users to obtain precise timing information about multiple acquisitions.

Multiple-Digitizer Synchronization

ATS660 features a Master/Slave connector that allows synchronization of multiple digitizers to allow truly synchronous sampling across as many as 8 channels.

A SyncBoard 660 (sold separately) is required to connect the Master/Slave connectors on multiple digitizers in the system together. Such a system is called a Master/Slave system.

SyncBoard 660 is available for 2 board synchronization or 4 board synchronization.

SyncBoard 660 is a board-level product that features clock buffering, clock distribution, trigger resynchronization and controlled impedance, equal length traces to deliver Positive Emitter Coupled Logic (PECL) level clock, trigger and initialization signals to each ATS660 in the system.

A Master/Slave system is guaranteed to sample simultaneously across all channels in that system. Triggering is also guaranteed to be simultaneous across all digitizers in the system, i.e. all boards will trigger on the same clock edge.

ATS660 based master/slave systems provide the best price-performance for high channel count systems.

Optional External Clock

While the ATS660 features low jitter, high reliability 125 MHz and 100 MHz oscillators as sources of the timebase system, there are occasions when ATS660 has to be synchronized to an external clock source.

ATS660 External Clock option provides an SMA input for an external clock signal, which can be a sine wave or LVTTTL signal.

Input impedance for the external clock input is fixed at 50Ω. Input coupling for the external clock is user-programmable between AC and DC coupling.

In order to operate the ADC under optimal conditions, the user must set the appropriate frequency range for the external clock being supplied. The following ranges are supported:

Fast External Clock: $1 \text{ MHz} < f_{\text{EXT}} < 125 \text{ MHz}$

Slow External Clock: $f_{\text{EXT}} < 10 \text{ MHz}$

Note that if user selects Medium External Clock (a type of clock available on ATS460), ATS660 software driver will automatically select Fast External Clock.

The active edge of the external clock is software selectable between the rising or falling edge.

10 MHz Clock Reference

Starting with ATS660 V1.1A hardware, it is possible to generate the sampling clock based on a 10 MHz reference input. This is useful for RF systems that use a common 10 MHz reference clock.

ATS660 uses an on-board PLL to generate the high frequency clock. Clock frequencies in the range of 110 MHz to 130 MHz can be generated with a 1 MHz resolution.

Slow External Clock

ATS660 uses ADC converters that cannot operate below 1 MHz clock frequency. For customers who have clocks that are slower than 1 MHz, AlazarTech has designed the powerful Slow External Clock.

Slow External Clock must be a 3.3 Volt LVTTTL signal. Sine wave or other types of signals are not allowed.

In this mode, the ADCs run at 125 MHz internal frequency, but the hardware detects a rising (or falling) edge of the incoming Slow External Clock and latches one sample point for each edge. This results in a sampling jitter of $\pm 8 \text{ ns}$, which may or may not be acceptable in a particular application.

AUX Connector

ATS660 provides an AUX (Auxiliary) BNC connector that is configured as a Trigger Output connector by default.

When configured as a Trigger Output, AUX BNC connector outputs a 5 Volt TTL signal synchronous to the ATS660 sampling clock, allowing users to synchronize their test systems to the ATS660 Trigger and clock.

When combined with the Trigger Delay feature of the ATS660, this option is ideal for ultrasonic and other pulse-echo imaging applications.

Other uses of AUX connector include its use as a Trigger Enable input and Clock output.



ATS660

125 MS/s 16-Bit PCI Digitizer

Calibration

Every ATS660 digitizer is factory calibrated for gain and offset accuracy to NIST-traceable standards, using a Fluke 5820A oscilloscope calibrator. To recalibrate an ATS660, the digitizer must either be shipped back to the factory or a qualified metrology laboratory.

RoHS Compliance

ATS660 units built after June 2007 are fully RoHS compliant, as defined by Directive 2002/95/EC of the European Parliament and of the Council of 27 January 2003 on the restriction of the use of certain hazardous substances in electrical and electronic equipment.

All manufacturing is done using RoHS-compliant components and lead-free soldering.

AlazarDSO Software

ATS660 is supplied with basic version of AlazarDSO software at no extra charge. AlazarDSO allows the user to setup the acquisition hardware and capture, display, process and archive the acquired signals.

AlazarDSO (32-bit) is fully compatible with Windows XP x86 (32bit) as well as Windows 7 (32-bit). AlazarDSO is not compatible with Windows 98 SE.

AlazarDSO (64-bit) requires a 64-bit operating system, such as Windows 7 x64. AlazarTech recommends Windows 7 x64 for Master/Slave systems.

AlazarDSO also allows FFT, cursors, math functions, histograms, unattended archiving, signal file recall, on-line help, dual-port memory support and numerous other powerful features.

With the optional AlazarDSO: Stream To Disk module, users can also stream data to hard disk for very long captures.

Finally, AlazarDSO capabilities can be expanded using a Plug-In DLL that can do custom control and processing functions on captured data. AlazarDSO Plug-In Development Kit (sold separately) is required for writing a custom Plug-In.

AlazarDSO Plug-Ins

AlazarDSO capabilities can be expanded using a Plug-In DLL that can do custom control and processing functions on captured data. AlazarDSO Plug-In Development Kit (sold separately) is required for writing a custom Plug-In.

This unique capability can be very useful for customers who want to create custom data analysis and display applications without investing months of software development effort.

The user-selected Plug-In DLL is called by AlazarDSO each time it receives a new buffer of data. The Plug-In can then modify the data in any way it wants and have AlazarDSO display it.

An example of such a Plug-In is the Averaging Plug-In supplied with AlazarDSO. It can average multiple records captured by AlazarDSO into a single record.

Another example is the Acquire-At-Time Plug-In that allows the user to set an acquisition time based on GPS clock derived from a Trimble GPS module.

Other potential Plug-Ins can include FIR filtering, Co-adding for spectroscopy, Software DDC and so on.

It should be noted that a Plug-In DLL can only be a listener that responds to a call from AlazarDSO. It cannot initiate an action on its own.

ATS-SDK Software Development Kit

ATS-SDK Windows compatible software development kit (sold separately) allows programs written in C/C++/C# and MATLAB to fully control the ATS660.

Sample programs are provided to show how users can acquire data using single-port memory as well as dual port memory.

Asynchronous DMA sample programs are also supplied with ATS-SDK.

ATS-VI for LabVIEW

A set of high performance VIs for LabVIEW 7.1 and higher, called ATS-VI, can also be purchased. These vis support single-port memory access as well as all modes of dual-port memory (AutoDMA) accesses.

An AsyncDMA vi is also provided to show how users can take advantage of Asynchronous DMA.

ATS-Linux

AlazarTech offers ATS660 binary drivers for CentOS 6.3 x86_64 with kernel 2.6.32-279.5.2.el6.x86_64. These drivers are also 100% compatible with RHEL 6.3.

Also provided is a GUI application called AlazarFront-Panel that allows simple data acquisition and display.

Source code example programs are also provided, which demonstrate how to acquire data programmatically using a C compiler.

If customers want to use ATS660 in any Linux distribution other than the one listed above, they must purchase a license for Linux driver source code and compile the driver on the target operating system. A Non-Disclosure Agreement must also be executed between the customer's organization and AlazarTech.

All such source code disclosures are made on an as-is basis with limited support from the factory.



ATS660

125 MS/s 16-Bit PCI Digitizer

System Requirements

Personal computer with at least one free PCI slot, 512 MB RAM, 100 MB of free hard disk space

Power Requirements

+5V	2.5 A, typical for ATS660-8M 3.0 A, typical for ATS660-128M
	+5V voltage level must remain between the range of 4.75V to 5.20V at all times after power-on

Physical

Size	Single slot, half length PCI card (4.2 inches x 7.2 inches)
Weight	500 g

I/O Connectors

CH A, CH B, TRIG IN, TRIG OUT ECLK	BNC female connectors SMA female connector
--	---

Environmental

Operating temperature	0 to 55 °C
Storage temperature	-20 to 70 °C
Relative humidity	5 to 95%, non-condensing

Acquisition System

Resolution	16 bits
Bandwidth (-3dB)	
DC-coupled, 1M Ω	DC - 65 MHz
DC-coupled, 50 Ω	DC - 65 MHz
AC-coupled, 1M Ω	10 Hz - 65 MHz
AC-coupled, 50 Ω	100KHz - 65 MHz
Bandwidth flatness:	\pm 1dB
Number of channels	2, simultaneously sampled
Maximum Sample Rate	125 MS/s single shot
Minimum Sample Rate	1 KS/s single shot for internal clocking
Full Scale Input ranges	
1 M Ω input impedance:	\pm 200mV, \pm 400mV, \pm 800mV, \pm 2V, \pm 4V, \pm 8V, and \pm 16V, software selectable
50 Ω input impedance:	\pm 200mV, \pm 400mV, \pm 800mV, \pm 2V, and \pm 4V, software selectable
DC accuracy	\pm 2% of full scale in all input ranges
Input coupling	AC or DC, software selectable
Input impedance	50 Ω or 1M Ω \pm 1% in parallel with 50 pF \pm 10pF, software selectable
Input protection	
1M Ω	\pm 28V (DC + peak AC for CH A, CH B and EXT only without external attenuation)
50 Ω	\pm 4V (DC + peak AC for CH A, CH B and EXT only without external attenuation)

Amplifier Bypass Mode

Standard Feature	Yes
DIP Switch selectable	Yes, independently for each channel
Input Range	Approx. 550 mV rms
Input Coupling	DC, irrespective of the input coupling setting for the channel
Input Impedance	50 Ω , irrespective of the input impedance setting for the channel
Input bandwidth (-3dB)	85 MHz

On-Board Acquisition Memory System

Onboard acq memory	32 MB for ATS660-8M 512 MB for ATS660-128M
Acquisition Memory/ch	Up to 8 Million samples per channel for ATS660-8M Up to 128 Million samples per channel for ATS660-128M
Record Length	Software selectable with 16 point resolution. Record length must be a minimum of 256 points. Maximum record length is limited by the acquisition memory per channel.
Number of Records	Software selectable from a minimum of 1 to a maximum of 256,000 or (Acquisition Memory Per Channel / (Record Length+16)), whichever is lower
Pre-trigger depth	0 to (Record Length-64), software selectable with 16 point resolution
Post-trigger depth	Record Length - Pre-trigger depth

Timebase System

Timebase options	Internal Clock or External Clock (Optional)
Internal Sample Rates	125 MS/s, 100 MS/s, 50 MS/s, 20 MS/s, 10 MS/s, 5 MS/s, 2 MS/s, 1 MS/s, 500 KS/s, 200 KS/s, 100KS/s, 50 KS/s, 20KS/s, 10KS/s, 5 KS/s, 2KS/s, 1 KS/s
Internal Clock accuracy	\pm 25 ppm



ATS660

125 MS/s 16-Bit PCI Digitizer

Dynamic Parameters

Typical values measured using a randomly selected ATS660 with Amplifier Bypass Mode. Input was provided by a HP8656A signal generator, followed by a 9-pole, 1 MHz band-pass filter (TTE Q36T-1M-100K-50-720B). Input frequency was set at 1 MHz and output amplitude was 500 mV rms, which is approximately 95% of the 520 mVrms full scale input in Amplifier Bypass Mode.

SNR	72.9 dB
SINAD	72.3 dB
THD	-83 dB
SFDR	-82 dB

Note that these dynamic parameters may vary from one unit to another, with input frequency and with the full scale input range selected.

Optional ECLK (External Clock) Input

Signal Level	±200mV Sine wave or 3.3V LVTTTL
Input impedance	50Ω
Maximum frequency	125 MHz for Fast External Clock 40 MHz for Slow External Clock
Minimum frequency	1 MHz for Fast External Clock DC for Slow External Clock
Decimation factor	Software selectable from 1 to 100,000
Sampling Edge	Rising or Falling, software selectable

Triggering System

Mode	Edge triggering with hysteresis
Comparator Type	Digital comparators for internal (CH A, CHB) triggering and analog comparators for TRIG IN (External) triggering
Number of Trigger Engines	2
Trigger Engine Combination	OR, AND, XOR, selectable
Trigger Engine Source	CH A, CH B, EXT, Software or None, independently software selectable for each of the two Trigger Engines
Hysteresis	±5% of full scale input, typical
Trigger sensitivity	±10% of full scale input range. This implies that the trigger system may not trigger reliably if the input has an amplitude less than ±10% of full scale input range selected
Trigger level accuracy	±5%, typical, of full scale input range of the selected trigger source
Bandwidth	65 MHz
Trigger Delay	Software selectable from 0 to 9,999,999 sampling clock cycles
Trigger Timeout	Software selectable with a 10 us resolution. Maximum settable value is 3,600 seconds. Can also be disabled to wait indefinitely for a trigger event

ORDERING INFORMATION

ATS660-8M	ATS660-001
ATS660-128M	ATS660-010
ATS660: 8 Meg to 128 Meg Upgrade	ATS660-011
ATS660: External Clock Upgrade	ATS660-004
SyncBoard 660 2X	ATS660-006
SyncBoard 660 4X	ATS660-007
C/C++, VB SDK for ATS660	ATS660-SDK
LabVIEW VI for ATS660	ATS660-VI
Linux Driver for ATS660	ATS660-Linux
AlazarDSO: Streaming Module	ATS-STR
AlazarDSO: Plug-In Dev Kit	ATS-DSO-PDK

TRIG IN (External Trigger) Input

Input impedance	1 MΩ in parallel with 30pF ±10pF
Bandwidth (-3dB)	
DC-coupled	DC - 25 MHz
AC-coupled	10 Hz - 25 MHz
Input range	±5V or ±1V, software selectable
DC accuracy	±10% of full scale input
Input protection	±28V (DC + peak AC without external attenuation)
Coupling	AC or DC, software selectable

TRIG OUT Output

Connector Used	AUX I/O
Output Signal	5 Volt TTL
Synchronization	Synchronized to rising edge of sampling clock

Materials Supplied

- ATS660 PCI Card
- ATS660 Installation Disk (on USB Flash Drive)

Certification and Compliances

- CE Mark Compliance
- RoHS compliant
- All specifications are subject to change without notice*

Manufactured By:

Alazar Technologies Inc.

6600 TRANS-CANADA HIGHWAY, SUITE 310
POINTE-CLAIRE, QC, CANADA H9R 4S2

TOLL FREE: 1-877-7-ALAZAR
TEL: (514) 426-4899 FAX: (514) 426-2723

E-MAIL: info@alazartech.com