

- 2 channels sampled at 12-bit resolution
- 50 MS/s simultaneous real-time sampling rate on each input
- ± 40 mV to ± 20 V input range
- Up to 8 Million samples of on-board acquisition memory per channel
- AlazarDSO Oscilloscope Software
- Software Development Kit supports C/C++, C#, Python, MATLAB®, LabVIEW®
- Support for Windows & Linux

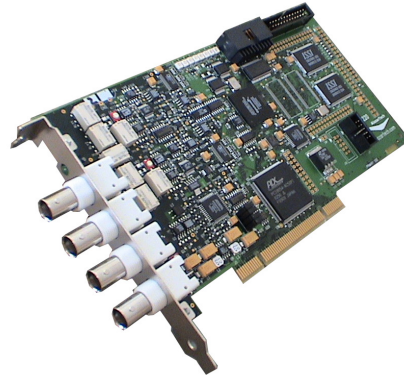

Product	Bus	Operating System	Channels	Sampling Rate	Bandwidth	Memory Per Channel	Resolution
ATS330	PCI 32 bit 33 MHz	Windows Linux 32-bit/64-bit	2	50 MS/s to 1 KS/s	25 MHz	128K Std. or 8M Optional	12 bits

Overview

ATS330 is a dual-channel, 12 bit, 50 MS/s waveform digitizer card for PCI bus, capable of storing up to 8 Million samples per channel of acquired data in its on-board memory.

It should be noted that it is not possible for ATS330 acquisition memory to be dual-ported. For applications that require dual port memory, consider using ATS460.

For scientific customers who want to record multiple analog inputs simultaneously, ATS330 offers multi-channel data acquisition systems of up to 8 channels.

ATS330 is supplied with AlazarDSO oscilloscope software that lets the user get started immediately without having to write any software.

Users who need to integrate the ATS330 in their own program can purchase a software development kit, ATS-SDK, for C/C++, C#, Python, MATLAB, and LabVIEW for both Windows and Linux operating systems.

All of this advanced functionality is packaged in a low power, half-length PCI card.

Applications

- Ultrasonic & Eddy Current NDT/NDE
- Motor Winding Testing
- High Resolution Oscilloscope
- Multi-Channel Transient Recording

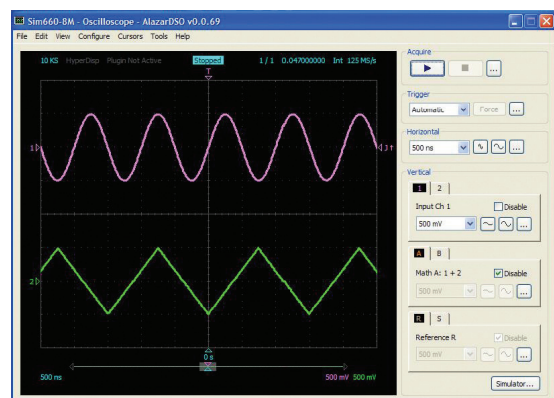

Analog Input

An ATS330 features two analog input channels with extensive functionality. Each channel has 25 MHz of full power analog input bandwidth. With software selectable attenuation, you can achieve an input voltage range of ± 40 mV to ± 20 V. Attenuating probes (sold separately) can extend the voltage range even higher.

Software selectable AC or DC coupling further increases the signal measurement capability. Software selectable 50Ω input impedance makes it easy to interface to high speed RF signals.

Acquisition System

ATS330 PCI digitizers use a pair of 50 MS/s, 12-bit ADCs to digitize the input signals. The real-time sampling rate ranges from 50 MS/s down to 10 KS/s. The two channels are guaranteed to be simultaneous, as they share the exact same clock.

An acquisition can consist of multiple records, with each record being captured as a result of one trigger event. Minimum number of records is 1 and maximum is 1000. A record may contain both pre-trigger and post-trigger data.

In between the multiple records being captured, the acquisition system is re-armed by the hardware within 8 sampling clock cycles. This mode of capture, sometimes referred to as Multiple Record or Pre-Trigger Multiple Record, is very useful for capturing data in applications with a very rapid trigger rate.

Examples of such applications include ultrasonic testing, NMR spectroscopy, motor testing and lightning test.

On-Board Acquisition Memory

The standard ATS330 PCI digitizer features 128 Kilo samples of acquisition memory for each channel.

Acquisition memory can optionally be upgraded to provide 8 Million samples per channel of signal storage.

Data is acquired into the onboard memory before being transferred to the host PC memory. This transfer is performed using Direct Memory Access (DMA), which uses scatter-gather bus mastering technology.

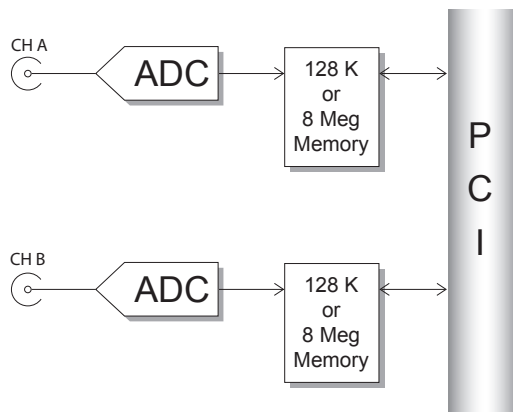

Triggering

The ATS330 is equipped with sophisticated digital triggering options, such as programmable trigger thresholds and slope on any of the input channels or the External Trigger input.

While most oscilloscopes offer only one trigger engine, ATS330 offers two trigger engines (called Engines X and Y). This allows the user to combine the two engines using a logical OR, AND or XOR operand.

The user can specify the number of records to capture in an acquisition, the length of each record and the amount of pre-trigger data.

A programmable trigger delay can also be set by the user. This is very useful for capturing the signal of interest in a pulse-echo application, such as ultrasound, radar, lidar etc.

Trigger Time Stamp

A 40-bit time stamp counter comes standard with the ATS330. By default, this counter is initialized to a zero value when an acquisition session is started and increments once for every two samples captured, thus providing a 2-clock timing accuracy. At 50 MS/s sample rate, this counter will not roll over for well over 2 hours.

The value of this counter is latched into trigger memory for each trigger, i.e. once per record, for up to specified number of records.

This allows the user to find out the timing of each trigger in a multiple record acquisition relative to the start of the acquisition.

It is also possible to configure the timestamp counter to reset for the first acquisition only and never again, until a software reset is issued. This feature enables users to obtain precise timing information about multiple acquisitions.

Multiple-Digitizer Synchronization

ATS330 features a Master/Slave connector that allows synchronization of multiple digitizers to allow truly synchronous sampling across as many as 8 channels.

A SyncBoard 330 (sold separately) is required to connect the Master/Slave connectors on multiple digitizers in the system together. Such a system is called a Master/Slave system.

SyncBoard 330 is available for 2 board synchronization or 4 board synchronization.

SyncBoard is a board-level product that features controlled impedance, equal length traces to deliver clock, trigger, and initialization signals to each ATS330 in the system.

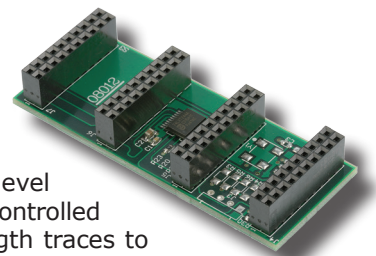



ATS330

50 MS/s 12-Bit PCI Digitizer

A Master/Slave system is guaranteed to sample simultaneously across all channels in that system. Triggering is also guaranteed to be simultaneous across all digitizers in the system.

Optional External Clock

While the ATS330 features a low jitter, high reliability 50 MHz crystal oscillator as the source of the timebase system, there may be occasions when digitizing has to be synchronized to an external clock source.

ATS330 External Clock option provides a BNC input for a TTL compatible external clock signal with a frequency between 50 MHz and 1 MHz.

This clock signal is terminated on the ATS330 printed circuit board using a 50 Ω resistor. As such, the external clock circuitry must have sufficient drive ($\pm 66\text{mA}$) to inject the clock signal properly.

The active edge of the external clock is software selectable between the rising or falling edge.

Users can also set a decimation factor for the external clock. For example, if the user wants to digitize the input signal on every tenth clock edge, this factor can be set to 10. Minimum decimation value is 1 and maximum is 100,000.

Optional Trigger Output

ATS330 can be optionally equipped with a Trigger Output capability. This option uses the ECLK BNC connector to output a TTL signal synchronous to the ATS330 Trigger signal, allowing users to synchronize their test systems to the ATS330 Trigger.

When combined with the Trigger Delay feature of the ATS330, this option is ideal for ultrasonic and other pulse-echo imaging applications.

Customers who want both External Clock and Trigger Output options on their ATS330 digitizers should contact the factory for arriving at an appropriate cabling solution.

Calibration

Every ATS330 digitizer is factory calibrated for gain and offset accuracy to NIST-traceable standards, using a Fluke 5820A oscilloscope calibrator. To recalibrate an ATS330, the digitizer must either be shipped back to the factory or a qualified metrology laboratory.

RoHS Compliance

ATS330 units built after June 2007 are fully RoHS compliant, as defined by Directive 2011/65/EU (RoHS 2) of the European Parliament and of the Council of 8 June 2011 on the restriction of the use of certain hazardous substances in electrical and electronic equipment.

All manufacturing is done using RoHS-compliant components and lead-free soldering.

AlazarDSO Software

ATS330 is supplied with the powerful AlazarDSO software that allows the user to setup the acquisition hardware and capture, display and archive the signals.

The Stream-To-Memory command in AlazarDSO allows users to stream a large dataset to motherboard memory.

AlazarDSO software also includes powerful tools for benchmarking the computer bus and disk drive.

Software Development Kits

AlazarTech provides easy to use software development kits for customers who want to integrate the ATS330 into their own software.

A Windows and Linux compatible software development kit, called ATS-SDK, includes headers, libraries and source code sample programs written in C/C++, C#, Python, MATLAB, and LabVIEW. These programs can fully control the ATS330 and acquire data in user buffers.

Linux Support

AlazarTech offers ATS330 binary drivers for most of the popular Linux distributions, such as CentOS, Ubuntu,...

Users can download the binary driver for their specific distribution by choosing from the available drivers here:

<ftp://release@ftp.alazartech.com/outgoing/linux>

Also provided is a GUI application called AlazarFront-Panel that allows simple data acquisition and display.

ATS-SDK includes source code example programs for Linux, which demonstrate how to acquire data programmatically using a C compiler.

If customers want to use ATS330 in any Linux distribution other than the one listed above, they can have the AlazarTech engineering team generate an appropriate driver for a nominal fee, if applicable.

Based on a minimum annual business commitment, the Linux driver source code license (order number ATS330-LINUX) may be granted to qualified OEM customers for a fee. For release of driver source code, a Non-Disclosure Agreement must be executed between the customer's organization and AlazarTech.

All such source code disclosures are made on an as-is basis with limited support from the factory.

Export Control Classification

According to the Export Controls Division of Government of Canada, ATS330 is currently not controlled for export from Canada. Its export control classification is N8, which is equivalent to ECCN EAR99. ATS330 can be shipped freely outside of Canada, with the exception of



ATS330

50 MS/s 12-Bit PCI Digitizer

countries listed on the [Area Control List](#) and [Sanctions List](#). Furthermore, if the end-use of ATS330, in part or in its entirety, is related to the development or deployment of weapons of mass destruction, AlazarTech is obliged to apply for an export permit.

EC Conformity

ATS330 conforms to the following standards:

Electromagnetic Emissions:

CISPR 22:2006/EN 55022:2006 (Class A):
Information Technology Equipment (ITE). Radio disturbance characteristics. Limits and method of measurement.

Electromagnetic Immunity:

CISPR 24:1997/EN 55024:1998 (+A1 +A2):
Information Technology Equipment Immunity characteristics — Limits and methods of measurement.

Safety:

IEC 60950-1:2005: Information technology equipment — Safety — Part 1: General requirements.

IEC 60950-1:2006: Information technology equipment — Safety — Part 1: General requirements.

ATS330 also follows the provisions of the following directives: 2006/95/EC (Low Voltage Equipment); 2004/108/EC (Electromagnetic Compatibility).

FCC & ICES-003 Compliance

ATS330 has been tested and found to comply with the limits for a Class A digital device, pursuant to part 15, subpart B of the FCC Rules, and the Canadian Interference-Causing Equipment Standard ICES-003:2004.



ATS330

50 MS/s 12-Bit PCI Digitizer

System Requirements

Personal computer with at least one free PCI slot, 512 MB RAM, 100 MB of free hard disk space

Power Requirements

+5 V 1.5 A, typical for ATS330-128K
1.7 A, typical for ATS330-8M
+5V voltage level must remain between the range of 4.75 V to 5.20 V at all times after power-on

Physical

Size Single slot, half length PCI card (4.225 inches x 7.7 inches excluding the connectors protruding from the front panel)
Weight 500 g

I/O Connectors

CH A, CH B, EXT, ECLK BNC female connectors

Environmental

Operating temperature 0 to 55 degrees Celsius
Storage temperature -20 to 70 degrees Celsius
Relative humidity 5 to 95%, non-condensing

Acquisition System

Resolution 12 bits
Data is returned as MSB-justified 16 bit unsigned integers

Bandwidth (-3 dB)
DC-coupled, 1 M Ω DC-coupled, 50 Ω AC-coupled, 1 M Ω AC-coupled, 50 Ω DC - 25 MHz DC - 25 MHz 10 Hz - 25 MHz 100 kHz - 25 MHz

Bandwidth flatness: ± 1 dB

Number of channels 2, simultaneously sampled

Maximum Sample Rate 50 MS/s single shot

Minimum Sample Rate 1 KS/s single shot for internal clocking

Full Scale Input ranges
1 M Ω input impedance: ± 40 mV, ± 50 mV, ± 80 mV, ± 100 mV, ± 200 mV, ± 400 mV, ± 500 mV, ± 800 mV, ± 1 V, ± 2 V, ± 4 V, ± 5 V, ± 8 V, and ± 10 V, software selectable
50 Ω input impedance: ± 40 mV, ± 50 mV, ± 80 mV, ± 100 mV, ± 200 mV, ± 400 mV, ± 500 mV, ± 800 mV, ± 1 V, ± 2 V, and ± 4 V, software selectable

DC accuracy $\pm 2\%$ of full scale in all input ranges

Input coupling AC or DC, software selectable

Input impedance 50 Ω or 1 M Ω $\pm 1\%$ in parallel with 50 pF ± 10 pF, software selectable

Input protection
1 M Ω ± 28 V (DC + peak AC for CH A, CH B and EXT only without external attenuation)
50 Ω ± 4 V (DC + peak AC for CH A, CH B and EXT only without external attenuation)

On-Board Acquisition Memory System

Onboard acq memory 512 Kilobytes for ATS330-128K
32 Megabytes for ATS330-8M

Acquisition Memory/ch Up to 128,000 samples per channel for ATS330-128K
Up to 8 Million samples per channel for ATS330-8M

Record Length Software selectable with 16 point resolution. Record length must be a minimum of 256 points. Maximum record length is limited by the acquisition memory per channel.

Number of Records Software selectable from a minimum of 1 to a maximum of 1000 or (Acquisition Memory Per Channel / (Record Length+4)), whichever is lower

Pre-trigger depth 0 to (Record Length-64), software selectable with 16 point resolution

Post-trigger depth Record Length - Pre-trigger depth

Timebase System

Timebase options Internal Clock or External Clock (Optional)

Internal Sample Rates 50 MS/s, 25 MS/s, 10 MS/s, 5 MS/s, 2 MS/s, 1 MS/s, 500 KS/s, 200 KS/s, 100 KS/s, 50 KS/s, 20 KS/s, 10 KS/s, 5 KS/s, 2 KS/s, 1 KS/s

Internal Clock accuracy ± 25 ppm

Dynamic Parameters

Typical values measured using a randomly selected ATS330 in ± 1 V input range, DC coupling and 50 Ω impedance. Input was provided by a HP8656A signal generator, followed by a 9-pole, 1 MHz band-pass filter. Input frequency was set at 1 MHz and amplitude was 650 mV rms (92% of full scale input).

SNR	60 dB
SINAD	58 dB
THD	-61 dB
SFDR	-62 dB

Note that these dynamic parameters may vary from one unit to another, with input frequency and with the full scale input range selected.

Optional ECLK (External Clock) Input

Signal Level TTL levels. Compatible with both 3.3 V and 5 V TTL

Input impedance 50 Ω

Input current requirement ± 66 mA

Maximum frequency 50 MHz with 50% $\pm 5\%$ duty cycle

Minimum frequency 1 MHz with 50% $\pm 5\%$ duty cycle

Decimation factor Software selectable from 1 to 100,000

Sampling Edge Rising or Falling, software selectable



ATS330

50 MS/s 12-Bit PCI Digitizer

Triggering System

Mode	Edge triggering with hysteresis
Comparator Type	Digital comparators for internal (CH A, CH B) triggering and analog comparators for TRIG IN (External) triggering
Number of Trigger Engines	2
Trigger Engine Combination	OR, AND, XOR, selectable
Trigger Engine Source	CH A, CH B, EXT, Software or None, independently software selectable for each of the two Trigger Engines
Hysteresis	$\pm 5\%$ of full scale input, typical
Trigger sensitivity	$\pm 10\%$ of full scale input range. This implies that the trigger system may not trigger reliably if the input has an amplitude less than $\pm 10\%$ of full scale input range selected
Trigger level accuracy	$\pm 5\%$, typical, of full scale input range of the selected trigger source
Bandwidth	25 MHz
Trigger Delay	Software selectable from 0 to 9,999,999 sampling clock cycles
Trigger Timeout	Software selectable with a 10 μ s resolution. Maximum settable value is 3,600 seconds. Can also be disabled to wait indefinitely for a trigger event

External Trigger Input

Input impedance	1.01 M Ω $\pm 10\%$ in parallel with 30 pF ± 10 pF
Bandwidth (-3 dB)	
DC-coupled	DC - 25 MHz
AC-coupled	10 Hz - 25 MHz
Input range	± 5 V or ± 1 V, software selectable
DC accuracy	$\pm 10\%$ of full scale input
Input protection	± 28 V (DC + peak AC without external attenuation)
Coupling	AC or DC, software selectable

Materials Supplied

- ATS330 PCI Card
- ATS330 Installation Disk (on USB Flash Drive)

Certification and Compliances

- RoHS 2 (Directive 2011/65/EU) Compliance
- CE Marking — EC Conformity
- FCC Part 15 Class A / ICES-003 Class A Compliance

All specifications are subject to change without notice

ORDERING INFORMATION

ATS330-128K	ATS330-001
ATS330-8M	ATS330-002
ATS330: 128K to 8 Meg Upgrade	ATS330-003
ATS330: External Clock Upgrade	ATS330-004
ATS330: TTL Trigger Output Upgrade	ATS330-005
SyncBoard 330 2x	ATS330-006
SyncBoard 330 4x	ATS330-007
ATS330-128K: One Year Extended Warranty	ATS330-061
ATS330-8M: One Year Extended Warranty	ATS330-062
Software Development Kit (Supports C/C++, Python, MATLAB, and LabVIEW)	ATS-SDK

Manufactured By:

AlazarTech

6600 TRANS-CANADA HIGHWAY, SUITE 310
POINTE-CLAIRE, QC, CANADA H9R 4S2

TOLL FREE: 1-877-7-ALAZAR
TEL: (514) 426-4899 FAX: (514) 426-2723

E-MAIL: sales@alazartech.com



DATASHEET REVISION HISTORY

Changes from version 1.3 (Sept 2017) to version 1.3A

	Section, Page
Added CNRC as calibration standard	Calibration, pg. 3
Corrected size of card	Physical, pg. 5
Updated email address	Manufactured By, pg. 6

Changes from version 1.2F (Nov 2013) to version 1.3

	Section, Page
Added Python to list of SDK supported languages, and Support for Windows & Linux	Features, pg. 1
Changed maximum number of channels for multi-channel data acquisition systems to 8	Overview, pg. 1
Removed note on availability of special order item for higher channel counts	Overview, pg. 1
Added Python & LabVIEW to list of supported languages for ATS-SDK, removed ATS-VI	Overview, pg. 1
Corrected maximum number of channels, 8 board synchronization deprecated	Multiple-Digitizer Synchronization, pg. 2
Added list of available SyncBoards	Multiple-Digitizer Synchronization, pg. 2
Updated section on RoHS compliance	RoHS Compliance, pg. 3
Modified AlazarDSO description	AlazarDSO Software, pg. 3
Removed section <i>AlazarDSO Plug-Ins</i> ; product deprecated	AlazarDSO Plug-Ins, pg. 3
New section <i>Software Development Kits</i> to replace sections: <i>ATS-SDK Software Development Kit</i> and <i>ATS-VI Software Development Kit</i>	Software Development Kits, pg. 3
Replaced section <i>ATS-Linux</i> with new <i>Linux Support</i> section	Linux Support, pg. 3
Added Export Control Classification information	Export Control Classification, pg. 3
Added section on EC Conformity	EC Conformity, pg. 4
Added section on FCC & ICES-003 Compliance	FCC & ICES-003 Compliance, pg. 4
Updated External Trigger Input Impedance to 1.01 M Ω \pm 10%	External Trigger Input, pg. 6
Updated list of Certification and Compliances	Certification and Compliances, pg. 6
Added products ATS330-061, ATS330-062	Ordering Information, pg. 6
Updated ATS-SDK and ATS330-005 product names	Ordering Information, pg. 6
Removed product ATS-VI (ATS-SDK now supports LabVIEW)	Ordering Information, pg. 6
Removed products ATS330-008, ATS330-Linux, ATS-DSO-PDK	Ordering Information, pg. 6