

- 2 channels sampled at 8-bit resolution
- 50 MS/s simultaneous real-time sampling rate on each input
- ± 20 mV to ± 20 V input range
- 256 kilo samples of on-board acquisition memory per channel
- AlazarDSO[®] oscilloscope software
- Software Development Kit supports C/C++, C#, Python, MATLAB[®], LabVIEW[®]
- Support for Windows[®] & Linux[®]

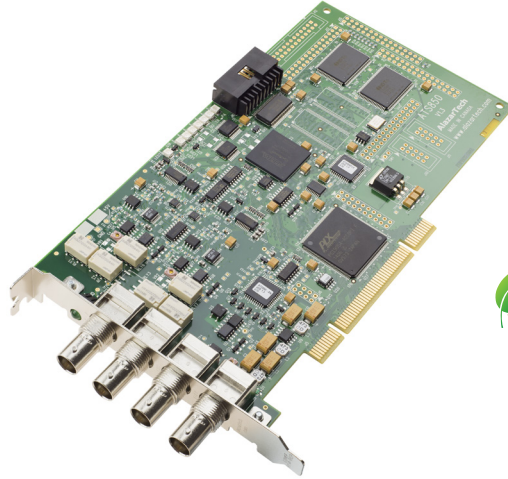

Product	Bus	Operating System	Channels	Max. Sample Rate	Bandwidth	Memory Per Channel	Resolution
ATS850	PCI 32 bit 33 MHz	32-bit/64-bit Windows & 64-bit Linux	2	50 MS/s	25 MHz	256 K	8 bits

Overview

AlazarTech ATS[®]850 is a dual-channel, 8 bit, 50 MS/s waveform digitizer card for PCI bus, capable of storing up to 256 kilo samples per channel of acquired data in its on-board memory.

It should be noted that it is not possible for ATS850 acquisition memory to be dual-ported. For applications that require dual-port memory, consider using ATS860.

For scientific customers who want to record multiple analog inputs simultaneously, ATS850 offers multi-channel data acquisition systems of up to 8 channels.

ATS850 is supplied with AlazarDSO oscilloscope software that lets the user get started immediately without having to write any software.

Users who need to integrate the ATS850 in their own program can purchase a software development kit, ATS-SDK, for C/C++, C#, Python, MATLAB, and LabVIEW for both Windows and Linux operating system.

All of this advanced functionality is packaged in a low-power, half-length PCI card available.

Applications

Motor Winding Testing

Ultrasonic & Eddy Current NDT/NDE

Low Cost Oscilloscope

Spectroscopy

Multi-Channel Transient Recording

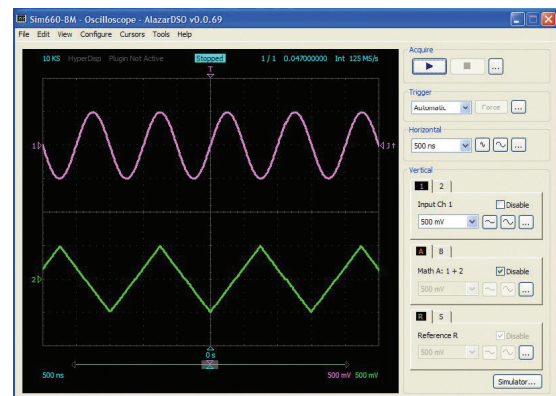

Analog Input

An ATS850 features two analog input channels with extensive functionality. Each channel has 25 MHz of full power analog input bandwidth. With software-selectable attenuation, you can achieve an input voltage range of ± 20 mV to ± 20 V. Attenuating probes (sold separately) can extend the voltage range even higher.

Software-selectable AC or DC coupling further increases the signal measurement capability. Software-selectable 50 Ω input impedance makes it easy to interface to high-speed RF signals.

Acquisition System

ATS850 PCI digitizers use a pair of 50 MS/s, 8-bit ADCs to digitize the input signals. The real-time sampling rate ranges from 50 MS/s down to 10 KS/s. The two channels are guaranteed to be simultaneous, as they share the exact same clock.

An acquisition can consist of multiple records, with each record being captured as a result of one trigger event. Minimum number of records is 1 and maximum is 1000. A record may contain both pre-trigger and post-trigger data.

In between the multiple records being captured, the acquisition system is re-armed by the hardware within 8 sampling clock cycles. This mode of capture, sometimes referred to as Multiple Record or Pre-Trigger Multiple Record, is very useful for capturing data in applications with a very rapid trigger rate.

Examples of such applications include ultrasonic testing, NMR spectroscopy, motor testing and lightning test.

On-Board Acquisition Memory

ATS850 PCI digitizer features 256 Kilo samples of acquisition memory for each channel.

Data is acquired into the onboard memory before being transferred to the host PC memory. This transfer is performed using Direct Memory Access (DMA), which uses scatter-gather bus mastering technology.

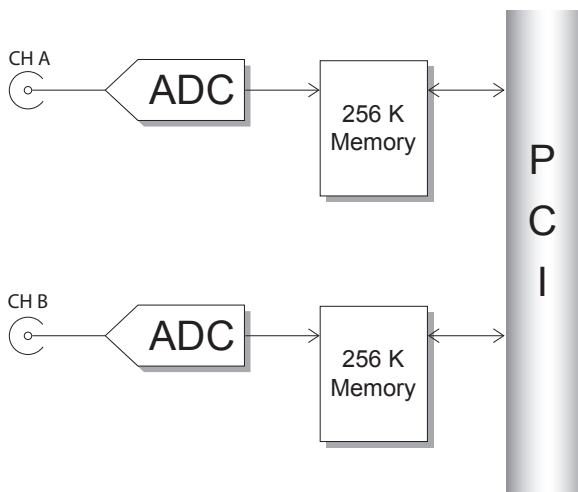

Triggering

The ATS850 is equipped with sophisticated digital triggering options, such as programmable trigger thresholds and slope on any of the input channels or the External Trigger input.

While most oscilloscopes offer only one trigger engine, ATS850 offers two trigger engines (called Engines J and K). This allows the user to combine the two engines using a logical OR, AND or XOR operand.

The user can specify the number of records to capture in an acquisition, the length of each record and the amount of pre-trigger data.

A programmable trigger delay can also be set by the user. This is very useful for capturing the signal of interest in a pulse-echo application, such as ultrasound, radar, lidar etc.

Trigger Time Stamp

A 40-bit time stamp counter comes standard with the ATS850. By default, this counter is initialized to a zero value when an acquisition session is started and increments once for every two samples captured, thus providing a 4-clock timing accuracy. At 50 MS/s sample rate, this counter will not roll over for well over 2 hours.

The value of this counter is latched into trigger memory for each trigger, i.e. once per record, for up to specified number of records.

This allows the user to find out the timing of each trigger in a multiple record acquisition relative to the start of the acquisition.

It is also possible to configure the timestamp counter to reset for the first acquisition only and never again, until a software reset is issued. This feature enables users to obtain precise timing information about multiple acquisitions.

Multiple-Digitizer Synchronization

ATS850 features a Master/Slave connector that allows synchronization of multiple digitizers to allow truly synchronous sampling across as many as 16 channels.

A SyncBoard 850 (sold separately) is required to connect the Master/Slave connectors on multiple digitizers in the system together. Such a system is called a Master/Slave system.

SyncBoard 850 is available for 2 board synchronization or 4 board synchronization.

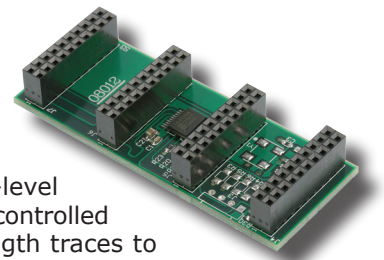

SyncBoard is a board-level product that features controlled impedance, equal length traces to deliver clock, trigger and initialization signals to each ATS850 in the system.



ATS850

50 MS/s 8-Bit PCI Digitizer

A Master/Slave system is guaranteed to sample simultaneously across all channels in that system. Triggering is also guaranteed to be simultaneous across all digitizers in the system.

Optional External Clock

While the ATS850 features a low-jitter, high-reliability 50 MHz crystal oscillator as the source of the timebase system, there may be occasions when digitizing has to be synchronized to an external clock source.

ATS850 External Clock option provides a BNC input for a TTL compatible external clock signal with a frequency between 50 MHz and 1 MHz.

This clock signal is terminated on the ATS850 printed circuit board using a 50 Ω resistor. As such, the external clock circuitry must have sufficient drive (± 66 mA) to inject the clock signal properly.

The active edge of the external clock is software-selectable between the rising or falling edge.

Users can also set a decimation factor for the external clock. For example, if the user wants to digitize the input signal on every tenth clock edge, this factor can be set to 10. Minimum decimation value is 1 and maximum is 100,000.

Calibration

Every ATS850 digitizer is factory calibrated for gain and offset accuracy to NIST- or CNRC-traceable standards. To recalibrate an ATS850, the digitizer must be shipped back to the factory.

RoHS Compliance

ATS850 units built after June 2007 are fully RoHS compliant, as defined by Directive 2015/863/EU (RoHS 3) of the European Parliament and of the Council of 31 March 2015 on the restriction of the use of certain hazardous substances in electrical and electronic equipment.

All manufacturing is done using RoHS-compliant components and lead-free soldering.

AlazarDSO Software

ATS850 is supplied with the powerful AlazarDSO software that allows the user to setup the acquisition hardware and capture, display and archive the signals.

The Stream-To-Memory command in AlazarDSO allows users to stream a large dataset to motherboard memory.

AlazarDSO software also includes powerful tools for benchmarking the computer bus and disk drive.

Software Development Kits

AlazarTech® provides easy-to-use software development kits for customers who want to integrate the ATS850 into their own software.

A Windows and Linux compatible software develop-

ment kit, called ATS-SDK, includes headers, libraries and source code sample programs written in C/C++, C#, Python, MATLAB, and LabVIEW. These programs can fully control the ATS850 and acquire data in user buffers.

The purchase of an ATS-SDK license includes a subscription that provides the following benefits for a period of 12 months from the date of purchase:

- Download ATS-SDK updates from the AlazarTech website;
- Receive technical support on ATS-SDK.

Customers who want to receive technical support and download new releases beyond this 12 month period should purchase extended support and maintenance (order number ATS-SDK-1YR).

Support for Windows

Windows support for ATS850 includes Windows 10, Windows 8.x, Windows 7 SP1 with security update KB3033929 (SHA-2 Code Signing Support), Windows Server 2012, Windows Server 2010, and Windows Server 2008 R2.

Microsoft support for Windows 7 and Windows Server 2008 R2 ends on January 14, 2020. As such, AlazarTech is ceasing development on Windows 7 and Windows Server 2008 R2 as of this date. We will continue to support customers using Windows 7 and Windows Server 2008 R2 until December 31, 2020. After this date, no support will be provided.

Due to lack of demand and due to the fact that Microsoft no longer supports these operating systems, AlazarTech no longer supports Windows XP, Windows Vista, and Windows Server 2008.

Linux Support

AlazarTech offers ATS850 binary drivers for the following Linux distributions: CentOS, Debian, and Ubuntu.

Users can download the binary driver for their specific distribution by choosing from the available drivers here:

<ftp://release@ftp.alazartech.com/outgoing/linux>

Also provided is a GUI application called AlazarFront-Panel that allows simple data acquisition and display.

ATS-SDK includes source code example programs for Linux, which demonstrate how to acquire data programmatically using a C compiler.

If customers want to use ATS850 in any Linux distribution other than the ones listed above, they can have the AlazarTech engineering team generate an appropriate driver for a nominal fee, if applicable.

Based on a minimum annual business commitment, the Linux driver source code license (order number



ATS850

50 MS/s 8-Bit PCI Digitizer

ATS850-LINUX) may be granted to qualified OEM customers for a fee. For release of driver source code, a Non-Disclosure Agreement must be executed between the customer's organization and AlazarTech.

All such source code disclosures are made on an as-is basis with limited support from the factory.

Export Control Classification

According to the Export Controls Division of Government of Canada, ATS850 is currently not controlled for export from Canada. Its export control classification is N8, which is equivalent to ECCN EAR99. ATS850 can be shipped freely outside of Canada, with the exception of countries listed on the [Area Control List](#) and [Sanctions List](#). Furthermore, if the end-use of ATS850, in part or in its entirety, is related to the development or deployment of weapons of mass destruction, AlazarTech is obliged to apply for an export permit.

EC Conformity

ATS850 conforms to the following standards:

Electromagnetic Emissions:

CISPR 22:2006/EN 55022:2006 (Class A):
Information Technology Equipment (ITE). Radio disturbance characteristics. Limits and method of measurement.

Electromagnetic Immunity:

CISPR 24:1997/EN 55024:1998 (+A1 +A2):
Information Technology Equipment Immunity characteristics — Limits and methods of measurement.

Safety:

IEC 60950-1:2005: Information technology equipment — Safety — Part 1: General requirements.

IEC 60950-1:2006: Information technology equipment — Safety — Part 1: General requirements.

ATS850 also follows the provisions of the following directives: 2006/95/EC (Low Voltage Equipment); 2004/108/EC (Electromagnetic Compatibility).

FCC & ICES-003 Compliance

ATS850 has been tested and found to comply with the limits for a Class A digital device, pursuant to part 15, subpart B of the FCC Rules, and the Canadian Interference-Causing Equipment Standard ICES-003:2004.



ATS850

50 MS/s 8-Bit PCI Digitizer

System Requirements

Personal computer with at least one free PCI slot, 512 MB RAM, 100 MB of free hard disk space

Power Requirements

+5 V 1.5 A, typical for ATS850-256K
 +5V voltage level must remain between the range of 4.75 V to 5.20 V at all times after power-on

Physical

Size Single slot, half length PCI card (4.225 inches x 7.7 inches excluding the connectors protruding from the front panel)
 Weight 500 g

I/O Connectors

CH A, CH B, EXT, ECLK BNC female connectors

Environmental

Operating temperature 0 to 55 degrees Celsius
 Storage temperature -20 to 70 degrees Celsius
 Relative humidity 5 to 95%, non-condensing

Acquisition System

Resolution 8 bits
 Bandwidth (-3 dB)
 DC-coupled, 1 M Ω DC - 25 MHz
 DC-coupled, 50 Ω DC - 25 MHz
 AC-coupled, 1 M Ω 10 Hz - 25 MHz
 AC-coupled, 50 Ω 100 kHz - 25 MHz
 Bandwidth flatness: ± 1 dB
 Number of channels 2, simultaneously sampled
 Maximum Sample Rate 50 MS/s single shot
 Minimum Sample Rate 1 KS/s single shot for internal clocking
 Full Scale Input ranges
 1 M Ω input impedance: ± 20 mV, ± 40 mV, ± 50 mV, ± 80 mV, ± 100 mV, ± 200 mV, ± 400 mV, ± 500 mV, ± 800 mV, ± 1 V, ± 2 V, ± 4 V, ± 5 V, ± 8 V, and ± 10 V, software-selectable
 50 Ω input impedance: ± 40 mV, ± 50 mV, ± 80 mV, ± 100 mV, ± 200 mV, ± 400 mV, ± 500 mV, ± 800 mV, ± 1 V, ± 2 V, and ± 4 V, software-selectable
 DC accuracy $\pm 2\%$ of full scale in all input ranges
 Input coupling AC or DC, software-selectable
 Input impedance 50 Ω or 1 M Ω $\pm 1\%$ in parallel with 50 pF ± 10 pF, software-selectable
 Input protection
 1 M Ω ± 28 V (DC + peak AC for CH A, CH B and EXT only without external attenuation)
 50 Ω ± 4 V (DC + peak AC for CH A, CH B and EXT only without external attenuation)

On-Board Acquisition Memory System

Onboard acq memory 512 Kilobytes for ATS850-256K
 Acquisition Memory/ch Up to 256,000 samples per channel for ATS850-256K
 Record Length Software-selectable with 16-point resolution. Record length must be a minimum of 256 points. Maximum record length is limited by the acquisition memory per channel.
 Number of Records Software-selectable from a minimum of 1 to a maximum of 1000 or (Acquisition Memory Per Channel / (Record Length+4)), whichever is lower
 Pre-trigger depth 0 to (Record Length-64), software-selectable with 16-point resolution
 Post-trigger depth Record Length - Pre-trigger depth

Timebase System

Timebase options Internal Clock or External Clock (Optional)
 Internal Sample Rates 50 MS/s, 25 MS/s, 10 MS/s, 5 MS/s, 2 MS/s, 1 MS/s, 500 KS/s, 200 KS/s, 100 KS/s, 50 KS/s, 20 KS/s, 10 KS/s, 5 KS/s, 2 KS/s, 1 KS/s
 Internal Clock accuracy ± 25 ppm

Dynamic Parameters

Typical values measured using a randomly selected ATS850 in ± 1 V input range, DC coupling and 50 Ω impedance. Input was provided by a HP8656A signal generator, followed by a 9-pole, 1 MHz band-pass filter. Input frequency was set at 1 MHz and amplitude was 650 mV rms (92% of full scale input).

SNR 42 dB
 SINAD 40 dB
 THD -46 dB
 SFDR -45 dB

Note that these dynamic parameters may vary from one unit to another, with input frequency and with the full scale input range selected.

Optional ECLK (External Clock) Input

Signal Level TTL levels. Compatible with both 3.3 V and 5V TTL
 Input impedance 50 Ω
 Input current requirement ± 66 mA
 Maximum frequency 50 MHz with 50% $\pm 5\%$ duty cycle
 Minimum frequency 10 kHz with 50% $\pm 5\%$ duty cycle
 Decimation factor Software-selectable from 1 to 100,000
 Sampling Edge Rising or Falling, software-selectable
 Maximum amplitude 2 Vp-p



ATS850

50 MS/s 8-Bit PCI Digitizer

Triggering System

Mode	Edge triggering with hysteresis
Comparator Type	Digital comparators for internal (CH A, CH B) triggering and analog comparators for TRIG IN (External) triggering
Number of Trigger Engines	2
Trigger Engine Combination	Engine J, engine K, J OR K, software-selectable
Trigger Engine Source	CH A, CH B, EXT, Software or None, independently software-selectable for each of the two Trigger Engines
Hysteresis	±5% of full scale input, typical
Trigger sensitivity	±10% of full scale input range. This implies that the trigger system may not trigger reliably if the input has an amplitude less than ±10% of full scale input range selected
Trigger level accuracy	±5%, typical, of full scale input range of the selected trigger source
Bandwidth	25 MHz
Trigger Delay	Software-selectable from 0 to 9,999,999 sampling clock cycles
Trigger Timeout	Software-selectable with a 10 µs resolution. Maximum settable value is 3,600 seconds. Can also be disabled to wait indefinitely for a trigger event

External Trigger Input

Input impedance	1 MΩ ±10% in parallel with 30 pF ±10 pF
Bandwidth (-3 dB)	
DC-coupled	DC - 25 MHz
AC-coupled	10 Hz - 25 MHz
Input range	±5 V or ±1 V, software-selectable
DC accuracy	±10% of full scale input
Input protection	±28 V (DC + peak AC without external attenuation)
Coupling	AC or DC, software-selectable

Materials Supplied

- ATS850 PCI Card
- ATS850 Installation Disk (on USB Flash Drive)

Certification and Compliances

- RoHS 3 (Directive 2015/863/EU) Compliance
- CE Marking — EC Conformity
- FCC Part 15 Class A / ICES-003 Class A Compliance

All specifications are subject to change without notice

ORDERING INFORMATION

ATS850-256K	ATS850-001
ATS850: External Clock Upgrade	ATS850-004
SyncBoard 850 2X	ATS850-006
SyncBoard 850 4X	ATS850-007
ATS850-256K: One Year Extended Warranty	ATS850-061
Software Development Kit 1 Year Subscription (Supports C/C++, Python, MATLAB, and LabVIEW)	ATS-SDK

† AlazarDSO, AlazarTech, and AlazarTech ATS are registered trademarks of Alazar Technologies Inc.
MATLAB is a trademark and/or registered trademark of The MathWorks, Inc.
LabVIEW is a trademark and/or registered trademark of National Instruments.
Windows and Windows Server are trademarks and/or registered trademarks of Microsoft Corporation in the U.S. and/or other countries.
Linux is a registered trademark of Linus Torvalds.
Radeon is a trademark of Advanced Micro Devices, Inc.
OpenCL is a trademark of Apple Inc.
All other trademarks are the property of their respective owners.

Manufactured By:

Alazar Technologies Inc.

6600 TRANS-CANADA HIGHWAY, SUITE 310
POINTE-CLAIRE, QC, CANADA H9R 4S2

TOLL FREE: 1-877-7-ALAZAR
TEL: (514) 426-4899 FAX: (514) 426-2723

E-MAIL: sales@alazartech.com

DATASHEET REVISION HISTORY

Changes from version 1.2E (Jan 2019) to version 1.2F

	Section, Page
Changed <i>Sampling Rate</i> column to <i>Max. Sample Rate</i>	Feature Table, pg. 1
Removed qualified metrology lab as option for recalibrating ATS850	Calibration, pg. 3
Specified Windows 7 version support, re-ordered list of operating systems, and added end-of-support notice for Windows 7 and Windows Server 2008 R2	Support for Windows, pg. 3
Specified Linux distributions: CentOS, Debian, and Ubuntu	Linux Support, pg. 3

Changes from version 1.3D (Jan 2019) to version 1.3E

	Section, Page
Updated <i>Sanctions List</i> URL	Export Control Classification, pg. 4

Changes from version 1.3C (Jan 2018) to version 1.3D

	Section, Page
Updated RoHS Compliance to RoHS 3	Global change
Updated product image	pg. 1
Clarified Operating System Support	Feature Table, pg. 1
Corrected trigger engines: changed to J and K (instead of X and Y)	Triggering, pg. 2
Removed <i>Optional Trigger Output</i> section, option is no longer available	Optional Trigger Output, pg. 3
Removed oscilloscope calibrator model	Calibration, pg. 3
Added information on ATS-SDK license	Software Development Kits, pg. 3
Added list of supported Microsoft Windows versions	Support for Windows, pg. 3
Added Maximum Amplitude: $2 V_{p-p}$	Optional ECLK (External Clock) Input, pg. 5
Corrected Trigger Engine Combination	Triggering System, pg. 6
Added subscription length for ATS-SDK	Ordering Information, pg. 6
Added Trademark information	pg. 6

Changes from version 1.3B (Sept 2017) to version 1.3C

	Section, Page
Added CNRC as calibration standard	Calibration, pg. 3
Corrected size of card	Physical, pg. 5
Updated email address	Manufactured By, pg. 6

Changes from version 1.3A (Jan 2013) to version 1.3B

	Section, Page
Added Python to list of SDK supported languages, and Support for Windows & Linux	Features, pg. 1
Changed maximum number of channels for multi-channel data acquisition systems to 8	Overview, pg. 1
Removed note on availability of special order item for higher channel counts	Overview, pg. 1
Added Python & LabVIEW to list of supported languages for ATS-SDK, removed ATS-VI	Overview, pg. 1
Corrected maximum number of channels, 8 board synchronization deprecated	Multiple-Digitizer Synchronization, pg. 2
Added list of available SyncBoards	Multiple-Digitizer Synchronization, pg. 2
Updated section on RoHS compliance	RoHS Compliance, pg. 3
Modified AlazarDSO description	AlazarDSO Software, pg. 3
Removed section <i>AlazarDSO Plug-Ins</i> ; product deprecated	AlazarDSO Plug-Ins, pg. 3
New section <i>Software Development Kits</i> to replace sections: <i>ATS-SDK Software Development Kit</i> and <i>ATS-VI Software Development Kit</i>	Software Development Kits, pg. 3
Replaced section <i>ATS-Linux</i> with new <i>Linux Support</i> section	Linux Support, pg. 3
Added Export Control Classification information	Export Control Classification, pg. 3
Added section on EC Conformity	EC Conformity, pg. 4
Added section on FCC & ICES-003 Compliance	FCC & ICES-003 Compliance, pg. 4
Updated External Trigger Input Impedance to $1 M\Omega \pm 10\%$	TRIG IN (External Trigger) Input, pg. 6
Updated list of Certification and Compliances	Certification and Compliances, pg. 6
Added product ATS850-061	Ordering Information, pg. 6
Updated ATS-SDK product name	Ordering Information, pg. 6



ATS850

50 MS/s 8-Bit PCI Digitizer

DATASHEET REVISION HISTORY

Changes from version 1.3A (Jan 2013) to version 1.3B (continued)	Section, Page
Removed product ATS-VI (ATS-SDK now supports LabVIEW)	Ordering Information, pg. 6
Removed products ATS850-005, ATS850-008, ATS850-Linux, ATS-DSO-PDK	Ordering Information, pg. 6